









## 5.6 Parameter Setting

Restore factory setting	Under off mode, hold both   for 3 seconds
Checking the version of software	Under off mode, hold both   for 3 seconds
Enter parameter setting as below	Under off mode, hold both   for 3 seconds; If no adjustment for address 1, hold both   to next address

Address	Description	Default Setting	Setting Range
1	Di2	100%	20~100%, by 5% increments
2	Di3	80%	20~100%, by 5% increments
3	Di4	40%	20~100%, by 5% increments
4	Self-priming/ Backwash capacity	100%	80~100%, by 5% increments
5	Control mode of Analog Input	0	0: current control 1: Voltage control

## 6. EXTERNAL CONTROL

External control can be enabled via following contacts. If more than one external control is enabled, the priority is as below: Digital Input > Analog Input > RS485 > Panel control

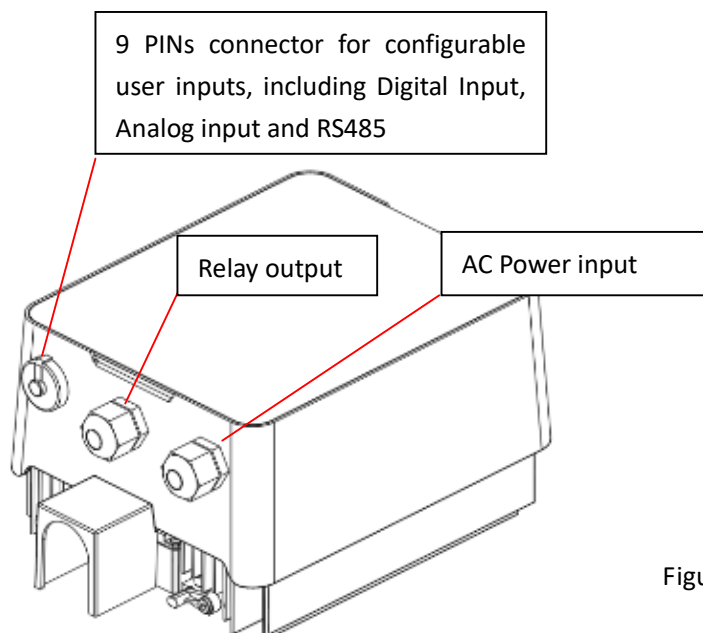

Figure 4

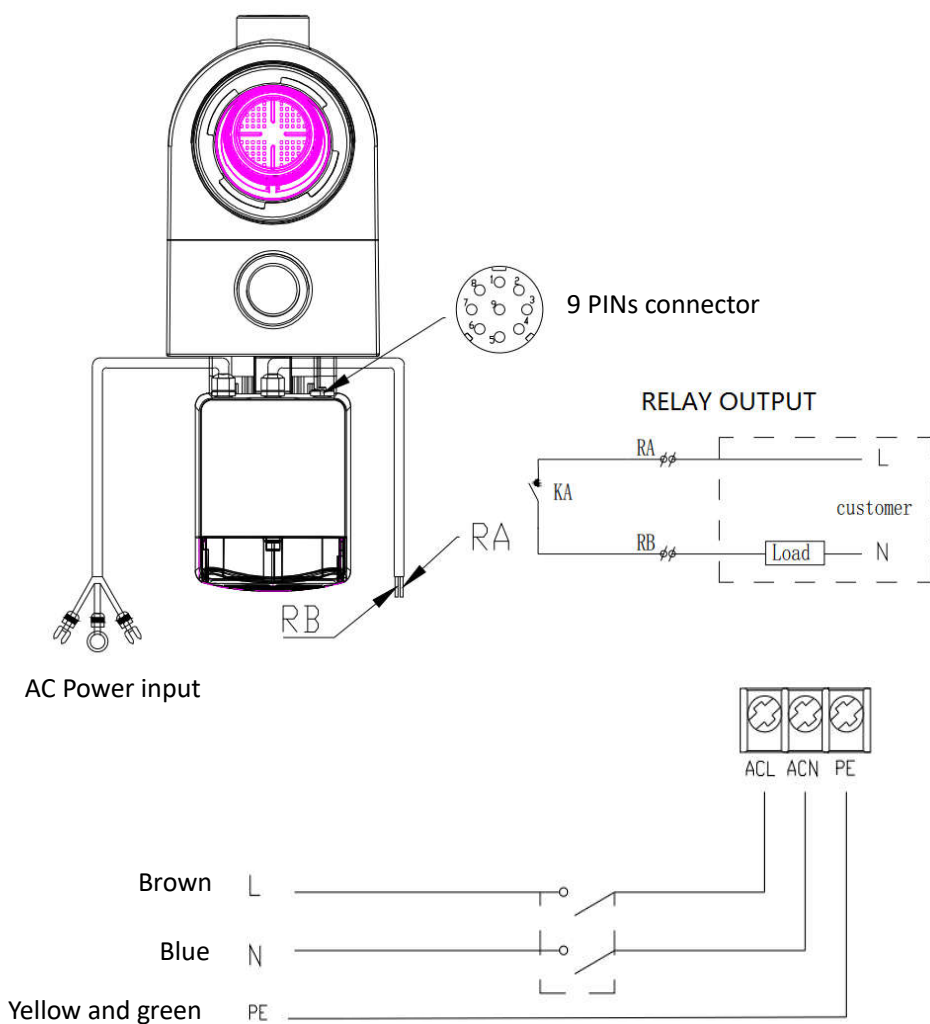

Figure 5

Name	Color	Description
PIN 1	Red	Digital Input 4
PIN 2	Black	Digital Input 3
PIN 3	White	Digital Input 2
PIN 4	Grey	Digital Input 1
PIN 5	Yellow	Digital Ground
PIN 6	Green	RS485 A
PIN 7	Brown	RS485 B
PIN 8	Blue	Anolog Input 0 (0-10V or 0~20mA)
PIN 9	Orange	Analog Ground

**a. Digital input:**

Running capacity determined by the state of digital input,  
When **PIN4** connect with PIN5, it means the pump stop running;  
When **PIN3** connect with PIN5, the pump runs at 100%;  
When **PIN2** connect with PIN5, the pump runs at 80%;  
When **PIN1** connect with PIN5, the pump runs at 40%;  
Capacity of inputs (**PIN1/PIN2/PIN3**) could be modified according to the parameter setting.

**b. Analog Input:**

To connect with PIN 8 and PIN 9, running capacity could be determined by 0~10V analog voltage signal or 0~20 mA analog current signal.  
Capacity to be controlled by voltage or current could be set according to the parameter setting

**c. RS485:**

To connect with PIN6 and PIN7, the pump could be controlled via Modbus 485 communication protocol.

**d. Relay output (optional):**

Connect terminal L & N to enable external control. An additional on-off Relay is necessary while bearing power is greater than 500W (2.5A).

## 7. PROTECTION AND FAILURE

Problem	Corrective solution
<b>Pump Does Not Start</b>	<ul style="list-style-type: none"><li>• Power Supply fault, disconnected or defective wiring.</li><li>• Fuses blown or thermal overload open.</li><li>• Check the rotation of the motor shaft for free movement and lack of obstruction.</li><li>• Because of long time lying idle. Unplug the power supply and manually rotate motor rear shaft a few times with a screwdriver.</li></ul>
<b>Pump Won't Prime</b>	<ul style="list-style-type: none"><li>• Empty pump/strainer housing. Make sure the pump/strainer housing is filled with water and the O ring of cover is clean.</li><li>• Loose connections on the suction side.</li><li>• Strainer basket or skimmer basket loaded with debris.</li><li>• Suction side clogged.</li><li>• Distance between pump inlet and liquid level is higher than 2.5m, height of pump installation should be lowered.</li></ul>